

VBK 710 Specifications

- 1 x 90mm Waste with Basket Strainer Waste and overflow. Capable of adaptation to take Waste Disposal Unit
- Creates a 'Farmhouse Look'
- Deep single bowl design
- Titanium available at extra cost

NB. Ceramic sinks may vary due to natural shrinkage in manufacture

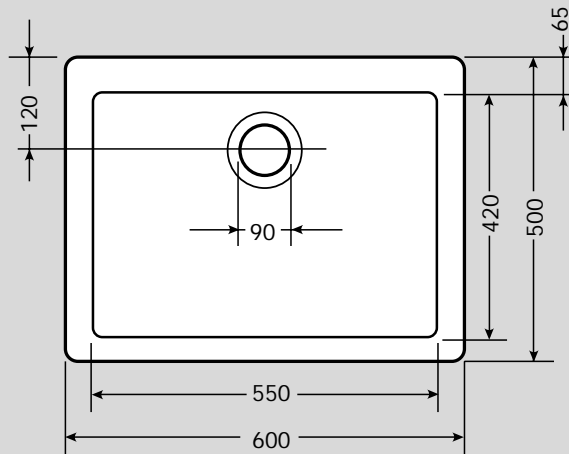

Materials: Fireclay Ceramic

Application: Stand alone

Bowl size: 550 x 420 x 170

Drainer Format: Not applicable

Cut-out size: N/A

Colour: White

Seal: Dependant on application

Insulation: Integral

Heat resistance: Up to 300°

Earthing Point: Not applicable

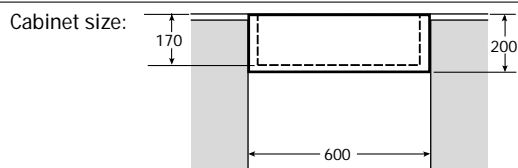

Fixing Clips: Not applicable

Plumbing Kit: 1 part

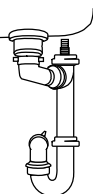

Waste: 2 x Lira 90mm Basket* Strainer Waste

Overflow:



*Zirconium finish option available at extra cost

Accessories:

Taps: Any Franke tap can be utilised with this model*.

*Ceramic disc taps in certain installations or where there is a low head of water (below 3 metres) may not provide adequate flow rates. You are advised to check with your supplier.

Guarantee: Franke sinks are guaranteed for 25 years against manufacturing defect. Franke taps are guaranteed against defective materials and workmanship for 1 year in relation to coatings and finishes, and 5 years in relation to moving parts. Franke will replace (and where appropriate repair) defective sinks. In relation to taps, Franke will where appropriate provide replacement parts for your taps or replace your taps. Any associated or ancillary costs to be incurred by you as a result of replacement of Franke sinks and taps under this guarantee shall in all cases be previously approved by Franke UK Limited.

This guarantee is in addition to and does not affect your statutory rights.